

GO-12-19-50-AC-STB  
GO-24-19-50-AC-ST



*Resistance  
Confidence  
Application anywhere*

## FIT FLOOR OUTDOOR ENCLOSURE



### **APPLICATION**

#### **Telecommunications Segment**

Versatile assembly, with agile and easy installation. Already ready for fixing to the floor with installation in concrete base or others.

#### **Energy Segment**

Resistance to vandalism, rails with depth regulation for more agility in the assembly of your equipment.

#### **Segment water supply**

Made of galvanized steel minimized with epoxy paint for protection against corrosion and bad weather.

#### **Telematic segment**

High degree of resistance and protection against corrosion. Efficient product for a demanding environment in the vicinity of roads and highways.

## MATERIAL

Minimized AISI -1020 galvanized steel.

## SURFACE

Electrostatic painting epoxy powder.

Resistance to corrosion, stains and chemicals.

Supports high and low temperatures, UV rays and humidity.

Impact resistance.

Galvanized rails.

## SCOPE OF SUPPLY

Designed according to IEC 6297-3-100 dimensions and mechanical structure of series 482.6 mm (19 ").

Outdoor product with automotive system seal on your door.

Wrench and drum with wrench. Prepared to receive padlock, with protection in Zamak and trivalent zinc and door in 180° opening.

Exhaust ventilation system, acts to capture heat from the inside and expel it to the external environment.

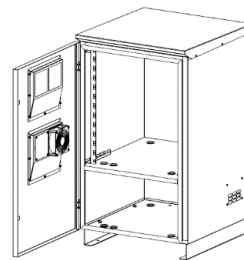
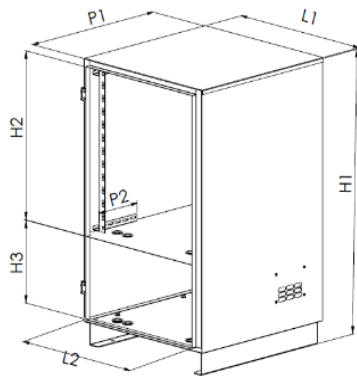

GO-12-19-50-AC-STB

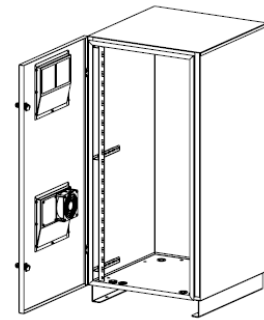

GO-24-19-50-AC-ST

Height (H1)	970 mm	1210 mm
Depth (P1)	590 mm	590 mm
Width (L1)	570 mm	570 mm
Useful height of equipment compartment (H2)	570 mm	1090 mm
Useful height of the battery compartment (H3)	295 mm	-
Rail adjustment depth (P2)	170 mm	170 mm
Internal depth (P3)	545 mm	545 mm
Useful door height (H2)	510 mm	510 mm
Volume	290 L	370 L
Weight	40 kg	45 kg
Volume with package	0,480 m <sup>3</sup>	0,580 m <sup>3</sup>
Weight with package	50 kg	55 kg
Package size	1050x700x650 mm	1280x700x650 mm

# OPTIONALS

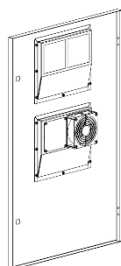

Additional refrigerator and thermostat.



Thermal blanket.

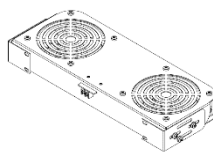

Forced ventilation.



Cable organizer.

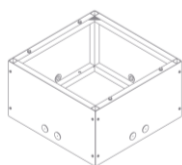

Anti-tumbled support

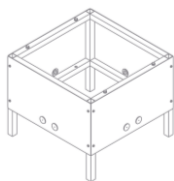

Feathered anti-tipped support for floor.

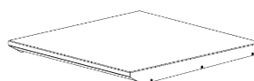

Top Cover.



Tray.

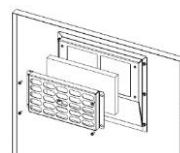

Air filter



Battery Compartment | Standard.  
GB-61-55-55-AC



Battery Compartment | Heavy.  
GB-82-70-74-AC

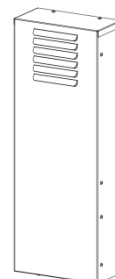

Heat Exchanger

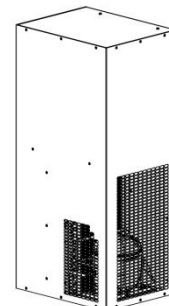

Air-conditioner



+55 54 3201.1903 | [algcom@algcom.com.br](mailto:algcom@algcom.com.br)  
Dalton Lahm dos Reis, 289 | Caxias do Sul - RS | Brasil | [www.algcom.com.br](http://www.algcom.com.br)

